

**HYDRAULIC EXCAVATOR**

**TAKEUCHI™**  
*From World First to World Leader*

# TB290-2 **english**



printed by: [www.arag-bau.ch](http://www.arag-bau.ch)



**Operating Weight: 8,400 kg**

# Product Features

## ENGINE

- EU Stage V / EPA Tier 4 Emission Compliant
- Turbocharged
- DOC + DPF Exhaust After Treatment
- Automatic Fuel Bleed System
- Double Element Air Cleaner
- Automatic Deceleration
- Working Modes: Standard, Eco, and High Altitude
- Engine Preheat
- High Capacity Radiator and Hydraulic Oil Cooler
- High Capacity Fuel Filters
- Fuel Supply Pump
- Engine Safety Start System on the Left Console
- Engine Auto Stop

## OPERATOR'S STATION

- Cab with Automatic Climate Control System, Windshield Wiper and Washer, Skylight with Sunshade, AM / FM / MP3 Bluetooth Radio, 12v Power Outlet
- ROPS / OPG (TOP Guard, Level I)
- Deluxe High Back Suspension Seat
- 2" Retractable Seat Belt
- Air Suspension Seat with Heat (optional)
- Rain Guard (optional)
- OPG Level II Roof Guard (optional)
- OPG Level II Front Guard (optional)

## UNDERCARRIAGE AND FRAME

- Triple Flanged Track Rollers
- 2-Speed Travel with Automatic Shift
- High Torque Planetary Final Drive
- Auto Track Tensioning
- Heavy Duty Dozer Blade with Float (optional)
- Large Wraparound Counterweight
- Extra Heavy Counterweight (optional)
- 450 mm Rubber Crawlers
- Steel Crawlers (450 mm / 550 mm) (optional)
- 450 mm Segmented Rubber Crawlers (optional)
- Rubber Pads for 450 mm Steel Crawlers (optional)
- Power Angle Blade with Float (optional)

## ELECTRICAL

- Multi-Informational Display
- Sealed Rocker Switches
- 12 volt System with 80 amp Alternator
- Rear View Camera
- Beacon Socket and Lamp Switch
- Halogen Work Lights
- LED Light Package 1 - Front Cover, Boom, and Front Cab (optional)
- LED Light Package 2 - Front Cover, Boom, Front Cab, and Rear Cab (optional)
- Additional Boom Light (optional)
- TFM (Takeuchi Fleet Management; GPS)\*
- TSS (Takeuchi Security System; Immobilizer) (optional)\*
- Travel Alarm (optional)
- Horn

## HYDRAULIC

- Closed Center, Load Sensing Hydraulics
- Hydraulic Joystick Controls
- Proportional Control for Service Port 1
- Detent for Service Port 1
- Proportional Control for Service Port 2
- Service Port 3 for Quick Hitch (optional)
- Proportional Control for Service Port 4 (optional)
- Adjustable Auxiliary Flow for Service Port 1, 2 and 4
- Auto Pressure Release (optional)
- Hydraulic Selector Valve (1-way / 2-way)
- Pilot Accumulator
- Air Breather, Hydraulic Tank
- Auto Tank (optional)

## WORKING EQUIPMENT

- Independent Mono Boom Swing
- 1,780 mm Arm
- 1,960 mm Arm
- 2,130 mm Arm
- 2-Piece Variable Angle Boom (optional)
- Cushioned Boom, Arm and Swing Cylinders
- Boom Holding Valve with Lift Alarm
- Pattern Change Valve (ISO or G) (optional)
- Arm Holding Valve (optional)
- Adjust Cylinder Holding Valve (optional)
- Boom Swing Stopper (optional)



Spacious Cabin



Automotive Styled Interior

\*Functions may not be available in all countries, so please consult your Takeuchi dealer for details.

# TOUGH, POWERFUL, RELIABLE



Large Floor with Foot Rest



Wraparound Counterweight

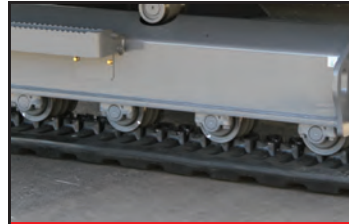

Triple Flange Track Rollers



Work Lights

The TB290-2 has a wide array of features that maximize efficiency and productivity. A closed center, load sensing hydraulic system allows the TB290-2 to have outstanding multi-function capabilities, and the attachment presets greatly expands the machines versatility. The cabin on the TB290-2 is spacious and well appointed. A large color monitor keeps the operator informed of critical machine functions. The auxiliary flow rates can be adjusted from the operator's seat.

Service and maintenance access is greatly enhanced with an engine and side cover that open high overhead for unmatched ground level serviceability. Key hydraulic components including the main control valve, hydraulic tank and sight gauge, and selector valve (1-way / 2-way) are mounted outboard for easier inspection and maintenance, and all daily inspection points for the engine can be easily accessed from the rear of the machine.



Large lockable service hoods provide vandalism protection and outstanding maintenance access.

# Product Specifications

## OPERATING PERFORMANCE

	Mono-Boom	2-Piece Boom
Operating Weight - Rubber Crawlers	8,400 kg	8,715 kg
Operating Weight - Steel Crawlers	8,635 kg	8,950 kg
Bucket Capacity (Heaped)	0.245 m <sup>3</sup>	
Slew Speed	10.3 min <sup>-1</sup>	
Travel Speed		
1st	2.6 km/h	
2nd	5.0 km/h	
Gradeability	35°	
Ground Pressure - Rubber Crawlers	37.6 kPa	39.0 kPa
Ground Pressure - Steel Crawlers	39.1 kPa	40.5 kPa
Maximum Bucket Breakout Force	59.1 kN	
Maximum Arm Digging Force (1,780 mm Arm)	40.0 kN	
Maximum Arm Digging Force (1,960 mm Arm)	37.9 kN	
Maximum Arm Digging Force (2,130 mm Arm)	36.3 kN	
Traction Force	88.0 kN	
Boom Swing Angle (Left/Right)	70° / 60°	

## ENGINE

Model	Yanmar / 4TNV98CT	
Rated Output (ISO 14396)	51.6 kW / 2,000 min <sup>-1</sup>	
Maximum Torque	308.0 Nm 1,300 min <sup>-1</sup>	
Displacement	3,318 ml	
Alternator	12 V - 0.96 kW	
Battery (IEC 60095-1)	12 V - 90 A·h	

## FLUID CAPACITY

Engine Lubrication	10.2 L
Cooling System	14.0 L
Fuel Tank Capacity	128.0 L
Hydraulic Reservoir Capacity	73.0 L
Hydraulic System Capacity	140.0 L

## HYDRAULIC SYSTEM

P1	Variable Displacement Pump
Flow Rate	224.0 L/min
Relief Pressure	27.5 MPa
P2	Gear Pump
Flow Rate	60.6 L/min
Hydraulic Pressure	24.0 MPa
Service Port 1	
Flow Rate	100.0 L/min
Hydraulic Pressure	20.6 MPa
Service Port 2	
Flow Rate	60.6 L/min
Hydraulic Pressure	20.6 MPa
Service Port 3	
Hydraulic Pressure	20.6 MPa
Service Port 4	
Flow Rate	60.6 L/min
Hydraulic Pressure	20.6 MPa

## SAFETY and HEALTH

Vibration Levels	
Hand / Arm	≤ 2.5 m/s <sup>2</sup>
Body	≤ 0.5 m/s <sup>2</sup>
Noise Level	
Sound Power Level	LWA 99 dB



Multi-Informational Display



Hydraulic Joystick Controls



Auxiliary Hydraulic Lines



Optional 2-Piece Boom

# TB290-2 Machine Dimensions

## Mono Boom

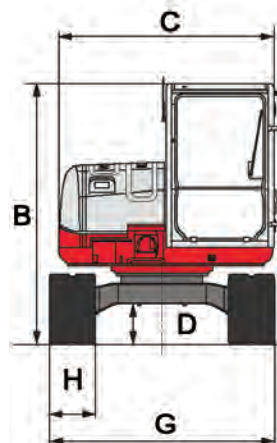
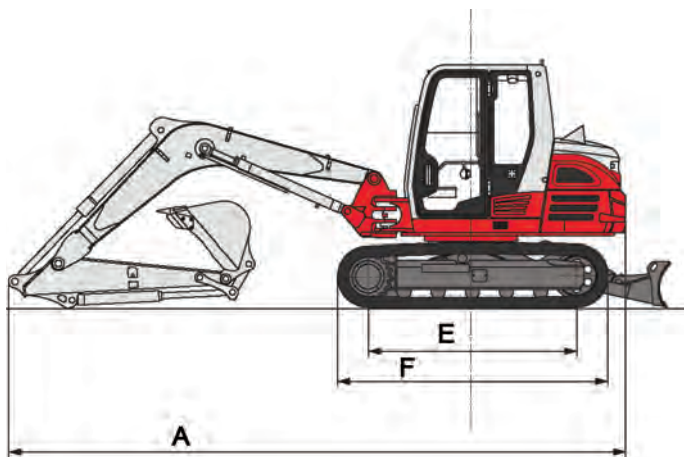

## 2 Piece Boom

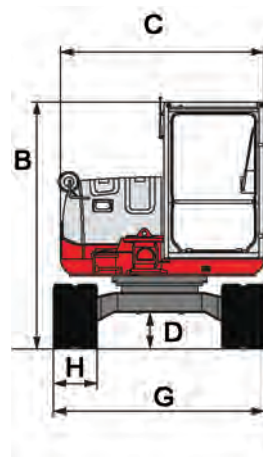
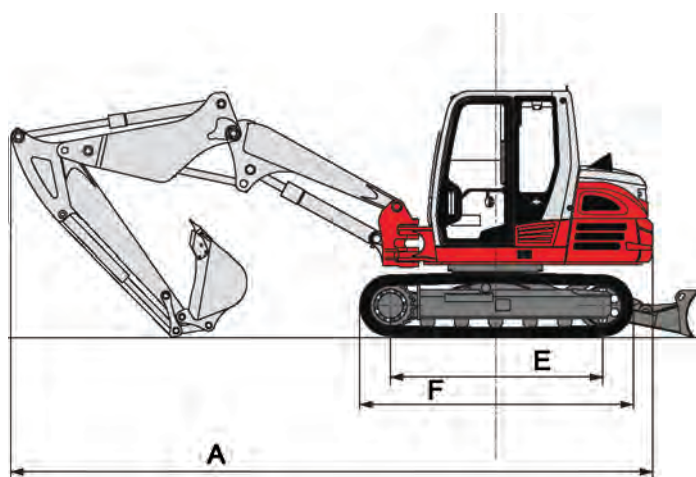

MACHINE DIMENSIONS	Mono Boom			2-Piece Boom
	1,780 mm ARM	1,960 mm ARM	2,130 mm ARM	
A Overall Length	6,530 mm	6,575 mm	6,660 mm	6,700 mm
B Overall Height	2,550 mm	2,550 mm	2,550 mm	2,550 mm
C Upper Structure Overall Width	2,140 mm	2,140 mm	2,140 mm	2,140 mm
D Ground Clearance	370 mm	370 mm	370 mm	370 mm
E Crawler Base	2,210 mm	2,210 mm	2,210 mm	2,210 mm
F Crawler Overall Length	2,855 mm	2,855 mm	2,855 mm	2,855 mm
G Crawler Overall Width	2,200 mm	2,200 mm	2,200 mm	2,200 mm
H Crawler Shoe Width	450 mm	450 mm	450 mm	450 mm

# TB290-2 Operating Dimensions

## Mono Boom

## 2 Piece Boom

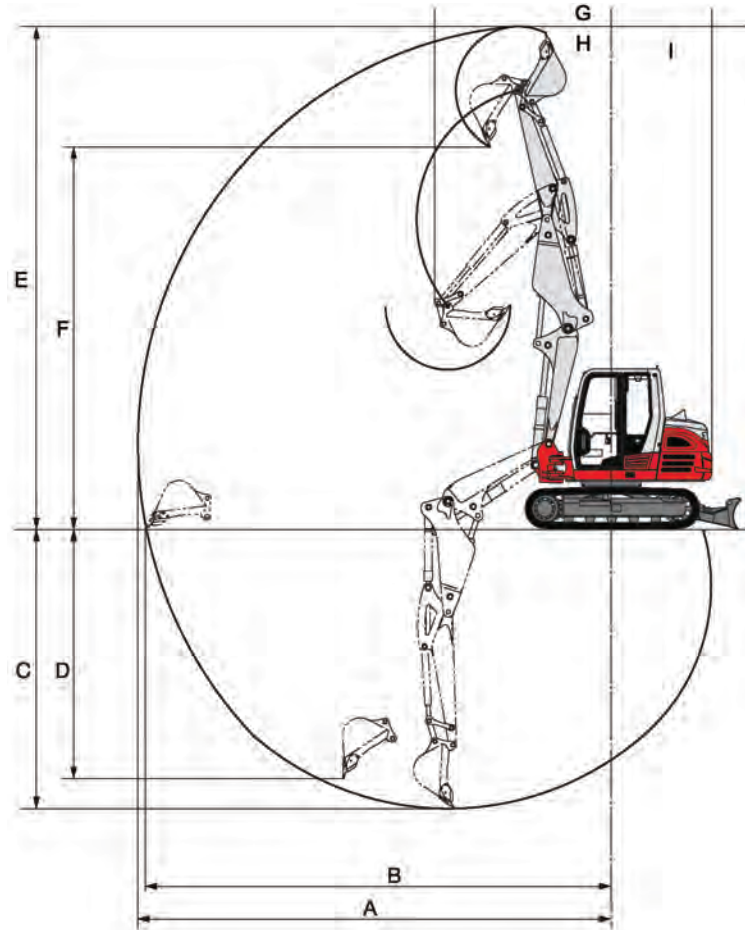
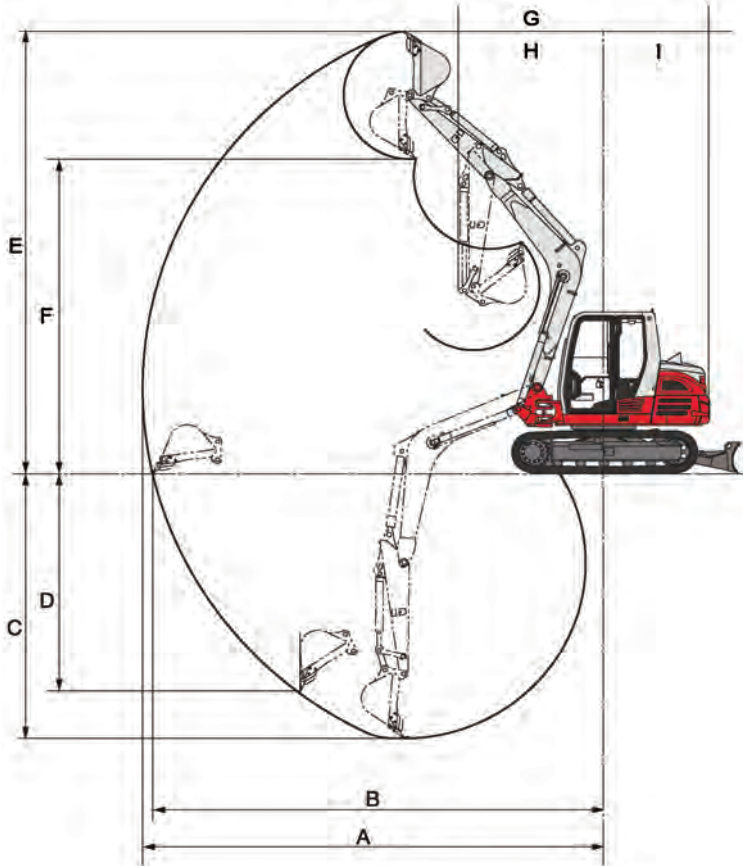

MACHINE DIMENSIONS	Mono Boom			2-Piece Boom
	1,780 mm ARM	1,960 mm ARM	2,130 mm ARM	
A Maximum Reach	7,105 mm	7,275 mm	7,435 mm	7,730 mm
B Maximum Reach at Ground Level	6,950 mm	7,125 mm	7,290 mm	7,590 mm
C Maximum Digging Depth	4,230 mm	4,410 mm	4,580 mm	4,470 mm
D Maximum Vertical Digging Depth	3,470 mm	3,650 mm	3,820 mm	3,980 mm
E Maximum Height of Cutting Edge	7,030 mm	7,165 mm	7,290 mm	8,045 mm
F Maximum Dumping Height	4,995 mm	5,135 mm	5,260 mm	6,120 mm
G Front Swing Radius	2,240 mm	2,360 mm	2,495 mm	2,675 mm
H Front Swing Radius with Boom Offset	1,810 mm	1,910 mm	2,030 mm	2,190 mm
I Slew Radius	1,650 mm	1,650 mm	1,650 mm	1,650 mm

# ARAG

ARAG Bau AG

Zinggen

6166 Hasle LU

[www.arag-bau.ch](http://www.arag-bau.ch)

Tel. 058 710 00 00

## Baumaschinen-Rent