

HSS SERIES

SHEARS
STAHLSCHEREN

Deutsch, english

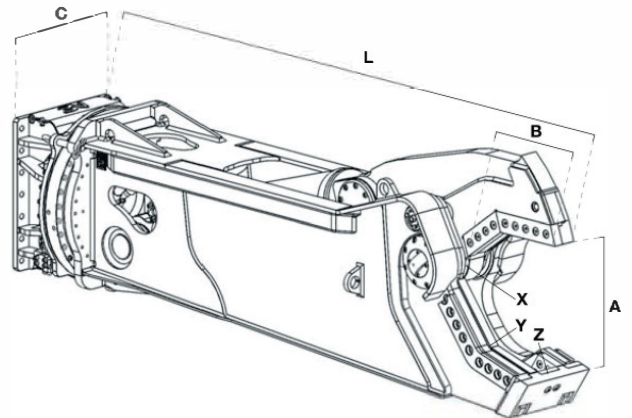

13 MODELS SCRAP / STEEL SHEARS FROM 300 UP TO 20.000 KGS FOR EXCAVATORS FROM 2 ~ 280 TONS

13 MODELLE STAHLSCHEREN VON 300 BIS ZU 20.000 KG FÜR BAGGER VON 2 BIS 280 TONNEN



gedruckt von: www.arag-bau.ch
printed from: www.arag-bau.ch

PRODUCT INFORMATION PRODUKTINFORMATIONEN



| | | HSS-3RV | HSS-5RV | HSS-8RV | HSS-12RV | HSS-18RV | HSS-25RV | HSS-30RV | HSS-40RV | HSS-55RV | HSS-70RV | HSS-90RV | HSS-160RV | HSS-200RV | |
|-----|---|---------|---------|---------|----------|----------|----------|----------|----------|----------|----------|----------|-----------|-----------|-----------|
| (1) | Baggerklasse/Excavatorclass | T. | 2 : 3 | 2,5 : 4 | 4 : 7 | 7 : 10 | 10 : 16 | 16 : 20 | 20 : 25 | 25 : 30 | 30 : 40 | 45 : 55 | 70 : 90 | 90 : 140 | 140 : 190 |
| ** | Baggerklasse/Excavatorclass | T. | 4 : 5 | 5 : 8 | 8 : 12 | 12 : 18 | 18 : 23 | 23 : 30 | 30 : 38 | 40 : 50 | 55 : 70 | 75 : 100 | 120 : 150 | 140 : 210 | 200 : 280 |
| *** | Gewicht / Weight | Kg. | 300 | 450 | 750 | 1180 | 1650 | 2350 | 2800 | 3900 | 5650 | 7180 | 9250 | 16500 | 19160 |
| A | | mm. | 265 | 340 | 405 | 475 | 535 | 575 | 615 | 680 | 780 | 845 | 920 | 1100 | 1180 |
| B | | mm. | 230 | 320 | 355 | 385 | 445 | 495 | 545 | 600 | 690 | 710 | 780 | 1080 | 1130 |
| C | | mm. | 380 | 460 | 460 | 570 | 715 | 715 | 715 | 865 | 1000 | 1100 | 1200 | 1325 | 1750 |
| L | | mm. | 1330 | 1725 | 2050 | 2300 | 2660 | 2900 | 3110 | 3420 | 3905 | 4190 | 4400 | 5440 | 5580 |
| | | T. | 28 | 35 | 65 | 72 | 80 | 140 | 170 | 200 | 215 | 280 | 355 | 460 | 480 |
| X | | T. | 95 | 125 | 210 | 225 | 250 | 460 | 550 | 600 | 700 | 815 | 1075 | 1495 | 1540 |
| Y | | T. | 45 | 50 | 90 | 95 | 110 | 210 | 230 | 270 | 290 | 375 | 480 | 610 | 690 |
| Z | | T. | 25 | 25 | 50 | 55 | 60 | 105 | 125 | 145 | 160 | 205 | 265 | 330 | 350 |
| | Arbeitsdruck / Workingpressure | Bar | 220 | 250 | 310 | 310 | 310 | 340 | 340 | 340 | 340 | 340 | 340 | 340 | 340 |
| | Ölvolumenstrom / Oilflow | L/min. | 80/100 | 80/150 | 100/150 | 150/250 | 180/250 | 200/300 | 200/300 | 300/400 | 400/500 | 450/600 | 500/800 | 700/1000 | 900/1200 |
| | Drehbar / Rotatable | | | | | | | | | | | | | | |
| | Arbeitsdruck beim rotieren / Workingpressure rotation | Bar | 120 | 120 | 120 | 140 | 140 | 140 | 140 | 140 | 140 | 140 | 140 | 140 | 140 |
| | Ölvolumenstrom beim rotieren / Oilflow rotation | L/min. | 5 | 10 | 10 | 10 | 10 | 10 | 10 | 10 | 10 | 10 | 50 | 50 | 50 |
| | Open/close (sec.) Öffnen/Schließen (sek.) | Sec. | 1,0/2,8 | 1,0/2,0 | 1,9/3,6 | 1,9/2,5 | 2,0/2,8 | 2,9/2,9 | 3,9/4,1 | 3,4/4,0 | 3,0/4,1 | 3,8/4,7 | - | - | - |

(*) Machinery class for mounting to main arm.

(***) The above mentioned weight is without connection plate

(*) Baggerklasse für Montage der Schere in Stiel-Position.

(***) Die oben genannten Gewichte beinhalten nicht die Baggeranbauplatte

(**) Machinery class for mounting on dipperstick

(1) Recommended excavator / attachment combination

(**) Baggerklasse für Montage der Schere in Löffel-Position.

(1) Empfohlene Bagger/Anbauteil Kombination

HCD-15R

| | | | |
|-----|---|--------|---------|
| (1) | Baggerklasse/Excavatorclass | T. | 16-25 |
| * | Gewicht / Weight | Kg. | 1520 |
| A | | mm. | 655 |
| B | | mm. | 2075 |
| C | | mm. | 130 |
| D | | mm. | 465 |
| X | | T. | 210 |
| Y | | T. | 95 |
| Z | | T. | 50 |
| | Arbeitsdruck / Workingpressure | Bar | 310 |
| | Ölvolumenstrom / Oilflow | L/min. | 180-250 |
| | Drehbar / Rotatable | | |
| | Arbeitsdruck beim rotieren / Workingpressure rotation | Bar | 140 |
| | Ölvolumenstrom beim rotieren / Oilflow rotation | L/min. | 10 |

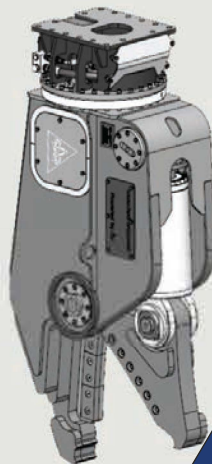

CAR DISMANTLERS | HCD-SERIES

AUTO-DEMONTAGE-SCHERE | HCD-SERIE

(*) The above mentioned weight is without connection plate

(1) Recommended excavator / attachment combination

(*) Die oben genannten Gewichte beinhalten nicht die Baggeranbauplatte

(1) Empfohlene Bagger/Anbauteil Kombination

ARAG
Baumaschinen-Rent

ARAG Bau AG
Zinggen
6166 Hasle LU
www.arag-bau.ch
Tel. 058 710 00 00