

JCB DUMPSTER | HTD5

English



printed from www.arag-bau.ch

ARAG Bau AG
Zürcher
8100 Hirschi 11
www.arag-bau.ch
Tel. 052 710 00 00

Baumaschinen-Rent



A Product
of Hard Work



Tight spaces and heavy loads. Trust JCB to carry it off.

The new HTD5 is a compact, walk-behind, high-tip Dumpster designed by JCB to save you time, energy and money: in independent tests Dumpsters were found to be over 20 times more effective than using the old-fashioned alternative, the wheelbarrow.

Where the HTD5 Dumpster really comes into its own is when paired with a JCB Micro excavator. Its compact dimensions, with a maximum width of just 690mm, allow it to follow the Micro through a standard doorway (typically 750mm wide) to access restricted sites like back gardens. Once in position the HTD5 Dumpster can be loaded directly by the excavator to remove spoil from the site.

Not only is this machine incredibly easy to use, even for novices, but 2-speed tracking also gives you a lower speed for added precision and control when going through tight spaces, and a faster speed for travelling across site, while a track lock as standard stops the machine creeping when parked on a hill. The engine cover helps to reduce noise levels for more comfortable operation and Cesar datatag, also as standard, increases security.

When it comes to unloading, the skip is operated hydraulically from below and is able to discharge from an exceptional tip height of 1450mm directly into a skip or a high-sided vehicle. Even more surprising for such a small machine is its large load capacity of 500kg.

Add an 850mm undercarriage for increased longitudinal stability, a 5.9hp diesel engine for economy and convenience on site, plus a choice of manual or electric start, and you have an indispensable partner for making light work of all sorts of carrying and unloading tasks.



Genuine go-anywhere productivity

When a product is designed and built by JCB, that's your guarantee of a robust, intelligently made machine that will give you the productive performance you need, backed up by the now legendary support and customer service of our global network. The HTD5 Dumpster comes with all of this and more.

Not only does this machine quietly get the job done... no fuss, just hard work. But you can also take it wherever you need it on a trailer or in the

back of a transit van, and carrying out maintenance and daily checks is simplicity itself thanks to a pull-out engine.

From local authorities and tool and plant hire businesses, to building and landscaping contractors, you'll find the HTD5 Dumpster indispensable when it comes to accessing restricted sites and smaller projects, such as drives, footings, patios, conservatories and paths.

FAST FACTS

- Maximum machine width of just 690mm fits through a standard doorway
- 1450mm tip height tips directly into a skip or high-sided vehicle
- High carrying capacity of 500kg lets you do more in less time
- Genuine JCB design and build guarantees quality and reliability
- Pull-out engine gives easy access for daily checks, servicing and maintenance





JCB GROUND CARE DUMPSTER | HTD5



MAX. ENGINE POWER: 4.4kW (5.9hp)
 MAX. CARRYING CAPACITY: 500kg (1102lb)
 MAX. SPEED: 4kph (2.5mph)

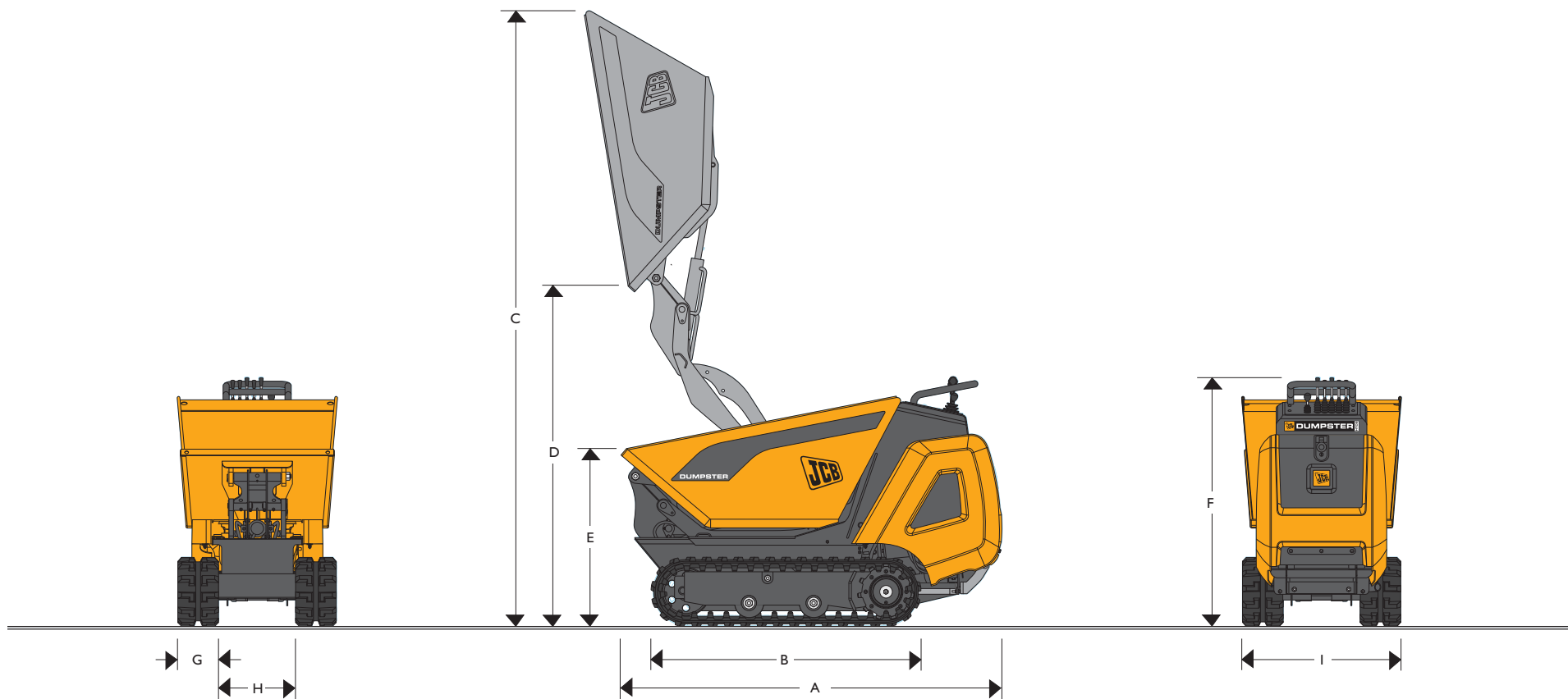

STATIC DIMENSIONS

Machine model	HTD5
	mm (ft-in)
A Machine length (operating position)	1700 (5-6)
B Undercarriage length	850 (2-9)
C Maximum height (tipping position)	2720 (9-0)
D Skip ground clearance (tipping position)	1450 (4-9)
E Skip height (transport position)	800 (2-7)

Machine model	HTD5
	mm (ft-in)
F Overall height (transport position)	1100 (3-7)
G Track width	180 (0-7)
H Inside track width	330 (1-0)
I Maximum machine width	690 (2-3)



JCB GROUND CARE DUMPSTER | HTD5



WEIGHTS & CAPACITIES

Machine weight	kg (lb)	475 (1047)
Max. carrying capacity	kg (lb)	500 (1102)
Max. operating weight (with load)	kg (lb)	975 (2150)
Fuel tank capacity	litres (in ³)	4.3 (262)
Hydraulic tank capacity	litres (in ³)	14 (854)

ENGINE (DIESEL)

Max. power	kW (hp)	4.4 (5.9)
Max. rpm		3000
Number of cylinders		1
Displacement	cm ³ (in ³)	349 (21)

HYDRAULICS

Pump number		3
Pump output	l/min (gal/min)	27 (6)
Operating pressure	bar	150

TRANSMISSION

Type – 2 speed hydrostatic

UNDERCARRIAGE

Number of bottom rollers		2
Track tensioning		Grease
Speed range	kph (mph)	0 – 4 (0 – 2.5)

STANDARD & OPTIONAL EQUIPMENT

0.3m ³ (0.4yd ³) skip		Std
2 speed tracking		Std
Manual pull start		Std
Electric start		Opt

THE BEST BACK-UP IN THE BUSINESS

Always on hand to help

You demand more from your machines than ever before: more efficiency, more reliability, more performance. That's why superb product support has never been so vital.



Together with our extensive dealer network, at JCB we're as innovative and forward-thinking when it comes to customer care as we are in machine development. Our product support and after-sales service have one aim: to give you peace of mind.

The care and quality we offer is exceptional. All servicing is carried out by the best, factory-trained JCB engineers.

Using the internet to pass vital information between on-site service personnel and our product support engineers, these professionals always have specialist information at their fingertips, so they can get you up and running again, faster.

Protect your machine and your cashflow

Everyone has individual needs and preferences. So we offer a range of service options all designed to help you cope with the unexpected and minimise costly downtime. Whether it's additional breakdown cover, an all-inclusive scheduled service programme, or servicing, we've got the best service option for you.



Finance packages, tailored to your needs

With ever-growing pressures on cashflows, the finance options available through JCB can provide a vital lifeline. Backed by JCB Finance, who can provide tax-efficient and cost-effective finance solutions, designed and tailored specifically to your needs.

Trust the genuine article

JCB parts are renowned worldwide for performance, reliability and safety. With replacement parts, we supply only the genuine

article, helping to safeguard the impressive residual values that you can expect in years to come.

As well as large stocks of parts engineered specifically for your machine, your JCB dealer also holds an extensive range of JCB: Filters, Lubricants, Grease, Wearparts, Tyres, Rubber Tracks and Service Exchange Components all manufactured to the same exacting standards. Your requirements can usually be supplied immediately by our dealers, but where this is not possible they can be ordered through the direct computer link between your dealer and JCB Service and processed through our impressive automated World Parts Centre warehouse. Despatch is normally the same day either to you or the dealer.

Whether we're providing you with support, parts or finance, we aim for 100% satisfaction. It's all part of our promise to put you, the customer, first.

ARAG Bau AG
Zinggen
6166 Hasle LU
www.arag-bau.ch
Tel. 058 710 00 00

Baumaschinen-Rent

JCB Sales Limited, Rocester, Staffordshire ST14 5JP. Tel: 01889 590312. Fax: 01889 590588. Web: <http://www.jcb.com>

©2008 JCB Sales. All rights reserved. No part of this publication may be reproduced, stored in a retrieval system, or transmitted in any form or by any other means, electronic, mechanical, photocopying or otherwise, without prior permission from JCB Service. JCB reserves the right to change specifications without notice. Illustrations & specifications shown may include optional equipment and accessories.

The JCB logo is a registered trademark of J C Bamford Excavators Ltd. Printed in the UK on paper made from sustainable forests. The pulp used in the manufacture of this paper is made from renewable timber produced on a fully sustainable basis, and is bleached without the use of chlorine gas (ECF - Elemental Chlorine Free). This paper is suitable for recycling. 9999/5365 02/08 Issue 1



**A Product
of Hard Work**