

EG40R/EG70R/EG110R

English

HITACHI

EG40R/EG70R/EG110R

Fully 360° Rotating Type Rubber Crawler Carriers

printed from www.arag-bau.ch



■ **Maximum Payload**

EG40R : 4 000 kg
EG70R : 6 500 kg
EG110R : 11 000 kg

■ **Maximum Travel Speed**

EG40R : 11 km/h
EG70R : 10 km/h
EG110R : 10 km/h



A Full 360° Rotation... Amazing Job Efficiency

A full 360° rotation of the upperstructure brings a new productivity. It allows efficient loading and dumping in all directions, and rearward travel with the operator facing in advancing direction. A big advantage from the new-generation rubber crawler carriers the EG40R, EG70R and EG110R.



A Full 360° Rotation Yields Higher Operating Efficiency

Boosted productivity

A full 360° rotation of the upperstructure reduces steering. This means less wear of rubber crawlers, longer life of undercarriage components, and less fuel consumption. There is no need for a U-turn.



Notes:
1. Pictures are for the sake of product explanation. When leaving the machine, follow proper safety procedure such as lowering the dump body.
2. Decal, caution plates and signs on monitor panel vary depending on countries. Pictured are those for the Japanese market.

Higher Durability, Less Running Costs

Rugged dump body using D-section frame

To improve durability, the dump body uses the D-section frame, already time-tested on Hitachi hydraulic excavators, at its sides, and high-tensile steel plates and well-arranged beams at its bottom.

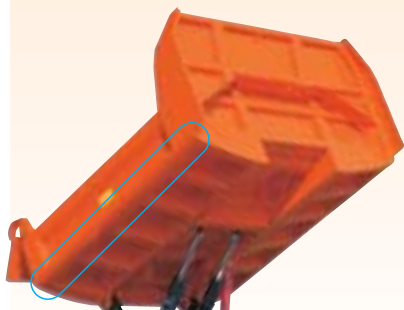

D-section frame on the EG40R

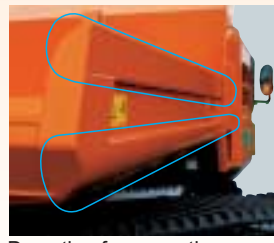

D-section frame on the EG70R / EG110R

Durable rubber crawlers (EG70R and EG110R)

Rubber crawlers are reinforced with high-tensile steel cores.

Strength: **30% increase over conventional machine**



Sturdy undercarriage

Lower rollers use large-size bearings. Track adjuster and bogies come from Hitachi hydraulic excavators.



Shortened Maintenance

Easy servicing and checking

The full-open hood gives easy access to the engine.

Engine oil filter, water separator, hydraulic oil filter and windshield washer water tank positioned for easy checking from ground.



EG40R



EG70R / EG110R
* Actual photo is of EG110R

Job-proven HN bushings

The Hitachi original HN bushings, employed at the bogie hinges, help extend lubricating intervals up to 500 hours.

Easy mud removal (EG70R / EG110R)

Large mud removal holes are provided to let mud remove easily.



Enhanced Safety and Operator Comfort

Improved right-side downward visibility

For better right-side downward visibility, the engine is centered on the EG40R, and mounted transversely on the EG70R and EG110R.



EG40R

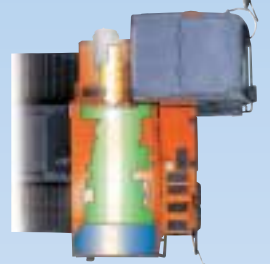

EG70R / EG110R
* Actual photo is of EG110R

Rearward-travel lamp and center lamp



EG40R
* Lit when the upper structure and undercarriage become paralleled.

Easy-to-read monitor panel

The monitor and switches are grouped for easy reading.



EG40R



EG70R / EG110R

CRES* cab (EG70R / EG110R)

The CRES cab, already used on the ZAXIS US hydraulic excavator series, is provided on the EG70R and EG110R.

*CRES : Corner Reinforced Structure



EG40R/EG70R/EG110R

Specifications

		EG40R	EG70R	EG110R
		Rear gate body	Scoop-end body	Scoop-end body
Operating weight	kg	6 200	10 800	16 100
Maximum payload	kg	4 000	6 500	11 000
Dump body capacity	struck/heaped m ³	1.55/2.51	2.20/3.76	4.06/6.87
Engine	Make and model	Isuzu A-4BG1T	Isuzu CC-6BG1T	Isuzu AA-6HK1TC
	Type	Water-cooled, 4-cycle, direct injection		
	Rated power kW/min ⁻¹ (PS/rpm)	73.6/2 000 (100/2 000)	132.6/2 200 (180/2 200)	183.9/2 000 (250/2 000)
Ground pressure	Displacement L(cc)	4.329 (4 329)	6.494 (6 494)	7.790 (7 790)
	Unloaded kPa(kgf/cm ²)	23 (0.24)	20 (0.20)	26 (0.26)
	Loaded kPa(kgf/cm ²)	38 (0.39)	32 (0.33)	43 (0.44)
Drive system	Fully hydraulic (2-pump 2-motor HST*)			
Shoe type	Steel-cored rubber shoes			
Shoe width	mm	500	700	800
Swing speed	min ⁻¹ (rpm)	7 (7)	4 (4)	3 (3)
Travel speeds	Low km/h	0-6.0	0-7.0	0-7.0
	High km/h	0-11.0	0-10.0	0-10.0
Fuel tank capacity	L	100	165	300

Data is expressed in SI units, followed by reference data in conventional units. * HST : Hydro Static Transmission

Options

- Scoop-end body for EG40R
- Rear gate body for EG70R and EG110R
- Steel-cab for EG40R
- Heater for EG40R (steel-cab)
- Strengthened bottom plate



Scoop-end body for EG40R (Option)

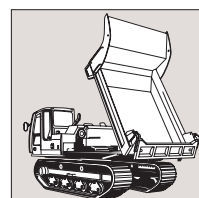

Rear gate body for EG70R and EG110R (Option)

Dimensions

Unit:mm

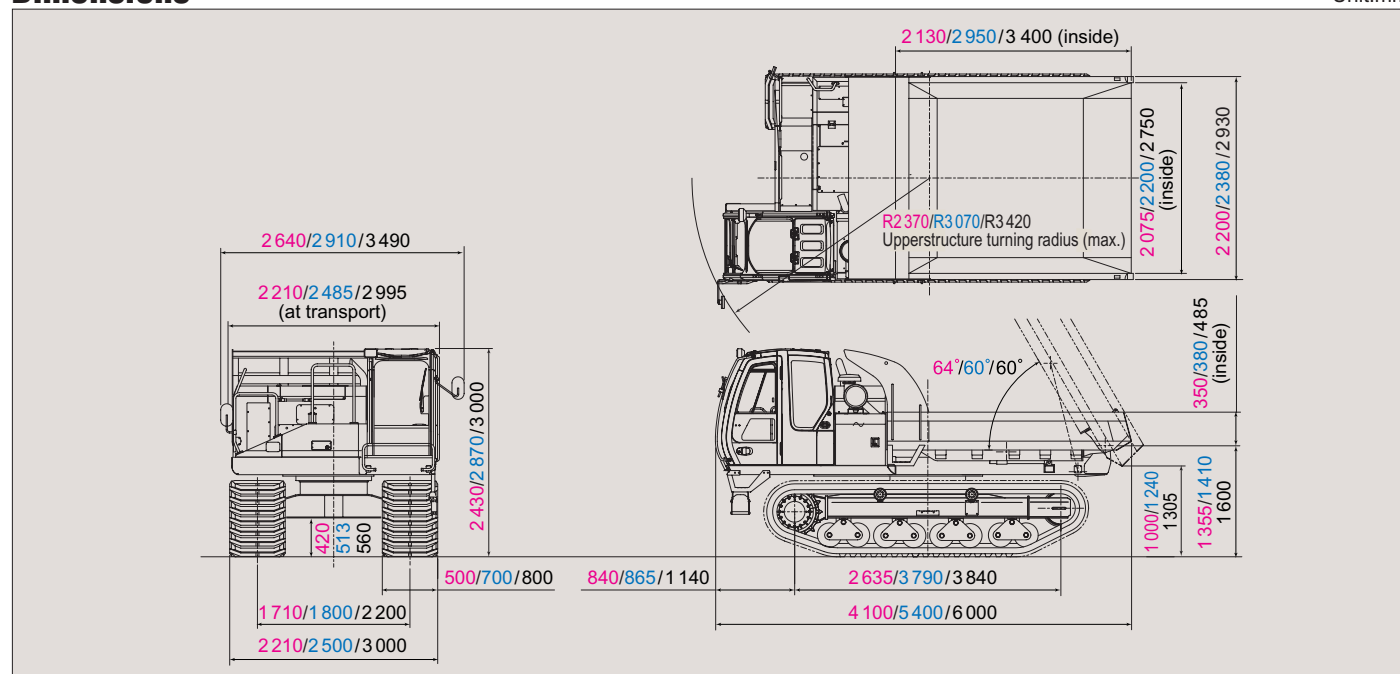

Notes: 1. Data on the EG40R is in red, and that on the EG70R in blue, and that on the EG110R in black.
2. The figure above shows the EG110R.

These specifications are subject to change without notice.
Illustrations and photos show the standard models, and may or may not include optional equipment, accessories, and all standard equipment with some differences in color and features.
Before use, read and understand Operator's Manual for proper operation.

Hitachi Construction Machinery Co., Ltd.

Head Office : 5-1 Koraku 2-chome, Bunkyo-ku,
Tokyo 112-8563, Japan
Telephone : 81-3-3830-8050
Facsimile : 81-3-3830-8204
URL : www.hitachi-c-m.com

ARAG ARAG Bau AG
Zinggen
6166 Hasle LU
www.arag-bau.ch
Tel. 058 710 00 00

Baumaschinen-Rent