



Machines

Hydrostatic Vibratory Plates 365–750 kg
APH 5020 / 6020 / 7010 / 1000 TC

www.ammann-group.com



Powerful compaction





Convincing compaction performance

High performance compaction, convenient operation, maximum efficiency

We present to you a fleet of powerful compaction machines for universal applications suitable to perform under the toughest site conditions: Models APH 5020, APH 6020 and APH 7010.

All three models are operating with the proven concept of a fully hydrostatic system. Without using V-belts the hydraulic pump drives the eccentric shaft as well as it controls the adjustment of the centrifugal weights to permit a smooth change of direction. The vibration plates can be operated easily and comfortably, even in tight areas, around columns and in cohesive material. The great advantage of a fully hydraulic system is the adjustment of the centrifugal force according to the condition of the job and the type of material by simply regulating the engine revolutions.

All models are fitted with a well-established and powerful Hatz Supra engine, equipped with automatic oil alert system.

Extension plates in 2 different sizes allow a wide field of applications with a variety of working widths.





Practical options

APH 5020 and APH 6020:

On both models the components are well protected by a foldable aluminium casing but easily accessible.

A range of useful options are available for these models:

- Electric starter
- Emergency stop at the end of the handle for a high operator's safety especially in narrow and deep trenches
- Dead man's handle with special handles: equipped with electronic sensors the touch by the operator will be registered and activates the hydraulic and exciter system – provided the electric emergency stop button has been pulled out – so that the machine is ready for operation. Releasing the handles leads to a stop of the machine after a few centimeters by an immediate deactivation of the hydraulic, the engine remains in idle drive. The handles are highly sensitive, the use of work gloves also does not pose a problem. A manipulation is virtually impossible and the operator is not restricted in his work and a tiresome restarting of the engine is unnecessary.

APH 7010: This vibration plate has been a proven compaction machine over several years. With a high amplitude and low frequency setting model APH 7010 is the ideal "problem solver" for all compaction work involving heavy soil with a high moisture content. An electric start system is available as option.



Dead man's handle with electronic sensors (Optional)



Functional design: the components are well protected and easily accessible



Electric starter (optional equipment)



Extension plates in two width sizes



Compaction with information

APH 5020 und APH 6020:

As an alternative to the ACE-system Ammann offers with the system 'ACEeco' the corresponding relative compaction control display. Hereby the operator is continuously informed about the achieved degree of compaction and the maximal feasible compaction.

'ACEeco' is available as option on models APH 5020 and 6020 (with electric starter only).



Compaction control system 'ACEeco' (Optional)





Freedom of movement thanks to remote control





Optimal compaction performance, operators safety first

Safety

Operators safety has increasingly become a deciding factor, particularly in underground working and trench construction. There are certain situations when compaction can be hazardous, despite high technical safety standards such as shuttering systems. AMMANN has developed a machine considering this criteria: The remote controlled vibratory plate model APH 1000 TC.

It achieves high compaction results, even in the deepest trenches and most impassable areas thanks to its high performance and to the compact design due to the powerful horizontally installed Hatz Supra 1 D 90 V Diesel engine. The operator controls the machine from a safe position, by either:

- Infrared remote control transmitter, which does not require recharging, due to its solar panel ensuring a constant readiness for use - max. distance between transmitter and machine is 18 metres.
- Cable control - max. possible distance transmitter and machine is 8 metres.

The APH 1000 TC operates on the proven principle of fully hydrostatic system, hydraulic drive of the exciter shafts, and hydraulic adjustment of centrifugal weights. This guarantees a quick response to the commands of the operator through the remote control transmitter - in case of emergency the machine can be stopped immediately. There are no wear and tear parts such as centrifugal clutches or V-belts.

All inclusive

Safety and easy operation are the focus of attention:

- The remote control transmitter is equipped with an emergency stop switch.
- The engine is started and stopped with the remote control unit, the engine start can be done in idle position.
- The vibration can be started and stopped at operator's request.
- The direction of movement can be rapidly altered as desired.
- A signal received acknowledgement light on the machine notifies the operator that the remote control unit is in infrared contact with the receiver on the plate. Should the operator loose contact with the machine it will automatically stop.
- A surrounding control system protects the operator: in case of a distance of less than 2 metres between user and machine the plate stops and cannot be restarted.
- The cable operation is controlled by the electric system being independent from the electronic system (can be necessary under very bad weather conditions when the remote control unit has to be recharged).
- An electronic shut off system protects the engine via solenoid in case of insufficient oil level, dirty air filter or overheating. The engine stops after repeated starting again.
- Considerably improved cleaning intervals of the air filter thanks to an optimised air stream guide system.
- Strong job site proven catches and hinges.
- Easy diagnosis of the electronic system with error memory report
- Simple, trouble-free cable installation.
- Storage of remote control unit and cable unit under the lookable rear cover.
- Excellent accessibility to all maintenance and service points.



Fully hydraulic and much more

A condensed overview of benefits and advantages

Protective casing: Protects functional components against dirt and damage, offers easy accessibility for service

Powerful, air-cooled and silenced Hatz diesel engines with oil alert system, low emissions values

Control handle bar: ergonomically adjustable and lockable, with Orbitrol providing drive control

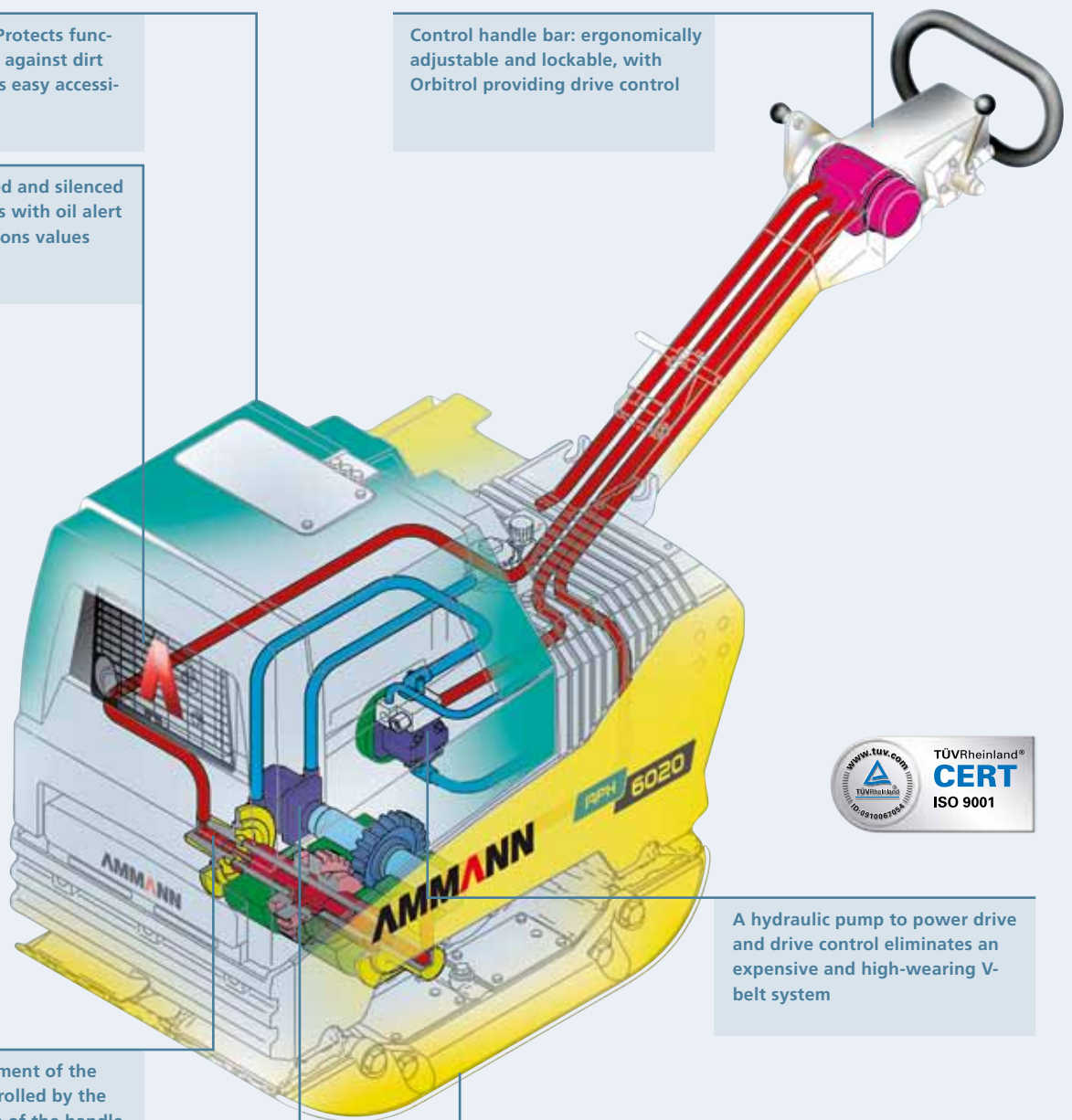

A hydraulic pump to power drive and drive control eliminates an expensive and high-wearing V-belt system

Hydrostatic adjustment of the exciter shafts controlled by the Orbitrol on the top of the handle bar

Hydrostatic motor drives the exciter shafts

Optimized shape of abrasion-resistant, self-cleaning cast iron base plates ensures balanced running performance, powerful drive and maximum gradient climbing capability



Technical Data

		APH 5020	APH 6020	APH 7010
		Hatz Diesel	Hatz Diesel	Hatz Diesel
Operating weight CECE basic unit	kg (lb)	365 (804)	440 (970)	620 (1367)
With extension plates	kg (lb)	385/400 (805/882)	490/500 (1080/1102)	660/680 (1455/1499)
With e-start	kg (lb)	+30 (66)	+30 (66)	+32 (71)
Working width basic unit	mm (in)	450 (18)	550 (22)	650 (26)
with extension plates	mm (in)	600/750 (24/30)	700/850 (28/33)	800/950 (31/37)
Engine		air-cooled Hatz-Diesel	air-cooled Hatz-Diesel	air-cooled Hatz-Diesel
Model		Supra 1 D 50 S	Supra 1 D 81 S	Supra 1 D 81 S
Power	HP (kW)	9,4 (7)	13,7 (10)	13,7 (10)
at speed	U/min. (rpm)	2700	3000	3000
Fuel capacity	l (gal)	5 (1,1)	7 (1,5)	10 (2,2)
Fuel consumption	l/h (gal/hr)	1,7 (0,4)	2,5 (0,6)	2,5 (0,6)
Centrifugal force up to	kN (lbf)	50 (11)	65 (15)	70 (16)
Vibration frequency up to	Hz (vpm)	65 (3900)	69 (4140)	46 (2760)
Compaction depth*	cm (in)	70 (28)	80 (31)	90 (35)
Operating speed*	m/min (mph)	26 (1)	28 (1)	28 (1)
Max. gradeability	%	36	36	36
Max. incline	°	30	30	30
Max. surface capacity basic unit	m ² /h (ft ² /hr)	650 (1399)	925 (1991)	1090 (2347)
with extension plates	m ² /h (ft ² /hr)	850/1050 (1830/2260)	1260/1430 (2712/3078)	1600 (3444)
Electric start		Optional equipment	Optional equipment	Optional equipment
Optional equipment				
extension plates	mm (in)	75/150 (3/5,9)	75/150 (3/5,9)	75/150 (3/5,9)
operating hour meter		x	x	x
compaction control system "ACEeco"		x	x	-
emergency stop		x	x	-
dead mans handle		x	x	-

*According to nature of soil

Specifications are subject to change due to technical improvements.

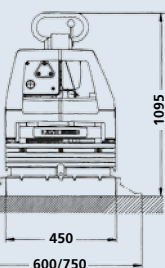
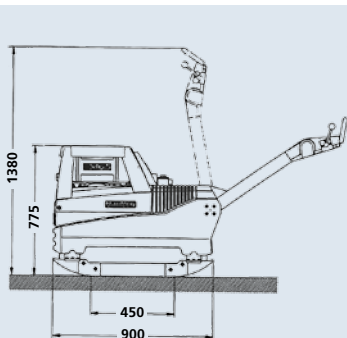

APH 5020

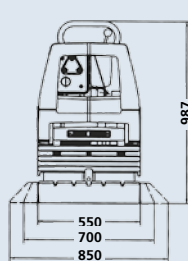
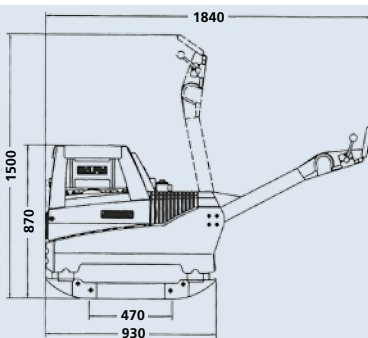

APH 6020

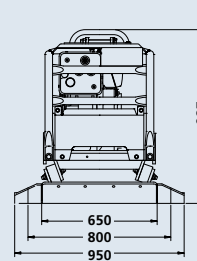
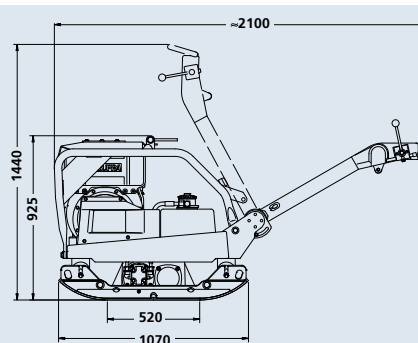

APH 7010



Fully hydraulic and much more

A condensed overview of benefits and advantages

Fully enclosed design: optimum protection against dirt and damage and excellent accessibility for maintenance

Extraordinary large air filter system with active dirt particle separation

Aircooled Hatz Diesel engine with oil alert system: powerful and low emissions values

A hydraulic pump to power drive and drive control eliminates an expensive and high-wearing V-belt system

Infrared receiver for the remote control with a signal acknowledgement light

Electromagnetic valves transmit the commands of the remote control from the black box into the hydraulic system

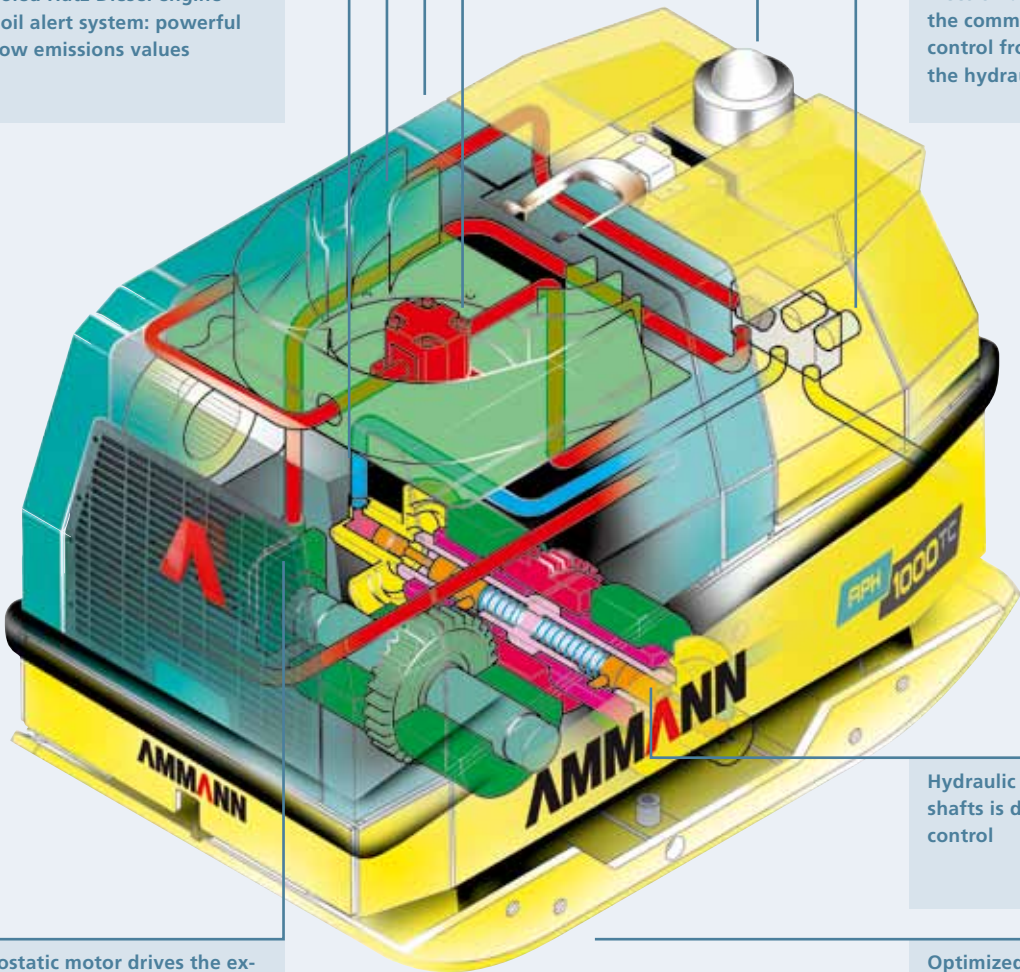

Hydrostatic motor drives the exciter shafts

Hydraulic change of the eccentric shafts is driven by the remote control

Optimized shape of base plate ensures balanced running performance, powerful drive and maximum gradient climbing capability



Technical data

APH 1000 TC

Operating weights CECE		
Basic unit	kg (lb)	710 (1565)
With extension plates	kg (lb)	750 (1653)
Working width		
Basic unit	mm (in)	650 (26)
With extension plates	mm (in)	800 (31)
Engine / Model		
		Air-cooled Hatz Diesel / 1 D 90 V
Power	HP (kW)	15,4 (10,9)
At speed	U/min. (rpm)	2900
Fuel capacity	l (gal)	10 (2,2)
Fuel consumption	l/h (gal/hr)	2,5 (0,6)
Centrifugal force up to	kN (lbf)	70 (15,7)
Vibration frequency up to	Hz (vpm)	46 (2760)
Compaction depth*	cm (in)	90 (35)
Operating speed*	m/min (mph)	28 (1)
Max. gradeability	%	35
Max. incline	°	25
Basic unit	m ² /h (ft ² /hr)	1090 (11733)
With extension plates	m ² /h (ft ² /hr)	1350 (14531)
Serial equipment		
		Infrared remote control and cable control
		Electric starter, extension plates 75 mm
Optional equipment		
		Operating hour meter

*according to nature of soil

Specifications are subject to change due to technical improvements.

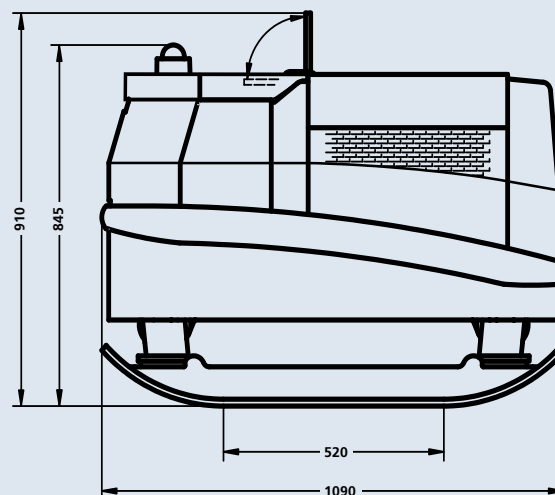
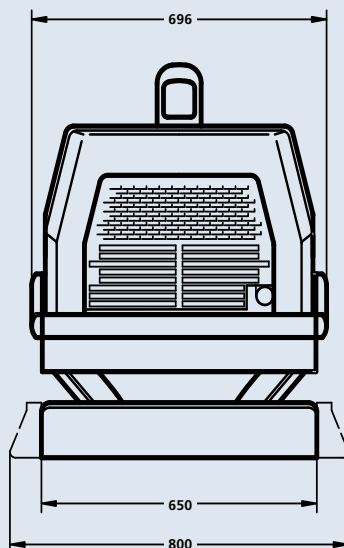

APH 1000 TC

Ammann distribution companies:

Germany:

Ammann Verdichtung GmbH
D-53773 Hennef
Tel +49 22 42 880 20
Fax +49 22 42 88 02 59
info.avd@ammann-group.com

France:

Ammann France SA
F-94046 Créteil/Cedex
Tel +33 1 45 17 08 88
Fax +33 1 45 17 08 90
info.afr@ammann-group.com

United Kingdom:

Ammann Equipment Ltd.
Bearley Stratford-upon-Avon
GB-Warwickshire, CV37 OTY
Tel +44 1789 414 525
Fax +44 1789 414 495
info.ael@ammann-group.com

USA:

Ammann America Inc.
Ponte Vedra, Florida 32082, USA
Tel +1 904 543 1691
Fax +1 904 543 1781
info@ammann-america.com

Poland:

Ammann Polska sp.zo.o.
02-230 Warszawa
Tel +48 22 33 77 900
Fax +48 22 33 77 929
info.aep@ammann-group.com

Russla:

Ammann Russland o.o.o.
RU-129343 Moskau
Tel +7 495 933 35 61
Fax +7 495 933 35 67
info.aru@ammann-group.com

Ammann manufacturing companies:

Switzerland:

Ammann Schweiz AG
CH-4901 Langenthal
Tel +41 62 916 63 56
Fax +41 62 916 64 03
info.aag@ammann-group.com

Germany:

Ammann Verdichtung GmbH
D-53773 Hennef
Tel +49 22 42 880 20
Fax +49 22 42 88 02 59
info.avd@ammann-group.com

Czech Republic:

Ammann Czech Republic a.s.
CZ-54901 Nové Město nad Metují
Tel +420 491 476 111
Fax +420 491 470 405
info.acz@ammann-group.com

ARAG

ARAG Bau AG

Zinggen

6166 Hasle LU

www.arag-bau.ch

Tel. 058 710 00 00

Baumaschinen-Rent

